



# Instructions

## Sportster Front Brake Reservoir Cover

### NOTE

**To prevent brake fluid spills, position motorcycle so that top of front master cylinder reservoir is level.**

**See figure 1 item 1.**

**BQUAZY Sportster recommends installation be done by qualified individuals.**

### Models

These Kits are designed to fit 2004 and later XL Sportster model motorcycles.

### Kit Contents

1 - Front Brake Reservoir Cover

1. Position motorcycle so the top of Front Master Cylinder Reservoir is level. See Figure 1 item 1. **This is necessary to prevent spilling of brake fluid. Brake fluid can be harmful to painted surfaces so take necessary precautions.**
2. Carefully, remove screws (figure 2 item 5). Original screws will have a smooth shank under the head with threads on the end. This is to aid in keeping the Diaphragm, Diaphragm Plate & Cover together as an assembly when removed (figure 2 items 2, 3 & 4).
3. Unscrew the Diaphragm Plate from the Cover.
4. Using the original screws, slip screws through new Cover and screw through Diaphragm Plate with Diaphragm attached to Plate creating a new Cover assembly.
5. Screw Cover assembly to Master Cylinder assembly. Tighten to 9-17 in-lbs. (1.0-2.0Nm)

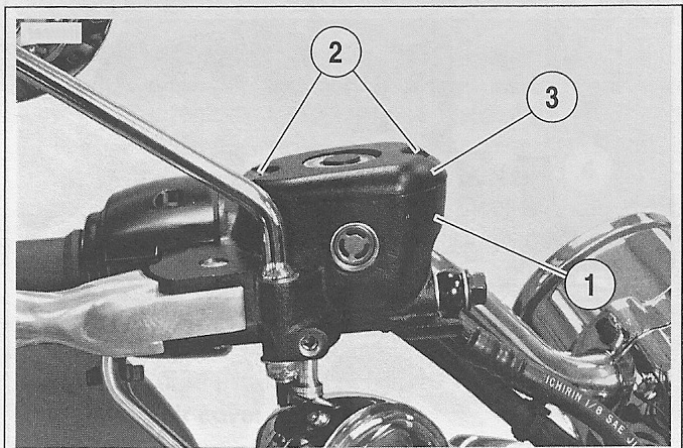

1. Front brake master cylinder and reservoir  
 2. Cover screw (2)  
 3. Top cover  
**Figure 1.**

1. Front brake master cylinder assembly
2. Diaphragm
3. Diaphragm plate
4. Reservoir cover
5. Screw (2)

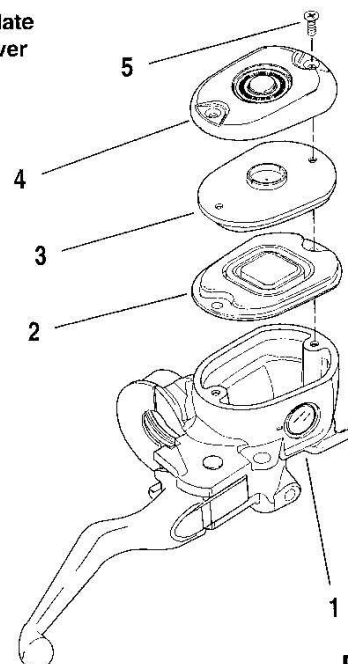

**Figure 2.**